

ADVANCED CONVERTING EQUIPMENT

## NEXUS<sup>®</sup> Technical data:

### Narrow web Gravure printing machine

- Web width..... 300- 600mm
- Max operating speed..... 250 m/min
- Print repeat..... 280 –550mm
- Unwinder diameter..... up to 1200 mm
- Rewinder diameter..... up to 1200 mm
- Electronic shaft..... NEXLOGIC
- Materials to print:
  - Aluminium..... from 9my
  - OPP/BOPP/METBOPP... from 15 my
  - PET/METPET..... from 12 my
  - PVC Shrink-twistable..... from 28 my
  - OPA/BOPA..... from 20 my
  - Paper..... from 28 gsm
  - Cardboard..... Up to 250 gsm
  - Laminates..... Up to 250 gsm

### Other features

- Digital tension control
- Automatic edge guiding system
- Digital AC motor drive SIEMENS
- Wide Touch Screen HMI 17"
- Operator friendly HMI - **NEXEASY<sup>®</sup>**
- Ethernet remote diagnostic
- Automatic register control – On request
- 100% inspection system
- Heating system: Electrical/Gas/thermal oil/ steam
- Unique combined flexo & gravure printing system on same print unit **TWINPRINT<sup>®</sup>**



TWINPRINT<sup>®</sup>

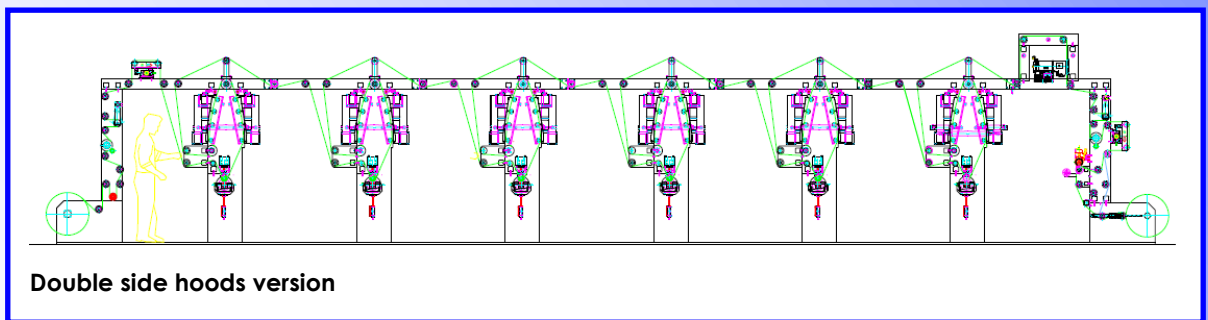

Double side hoods version

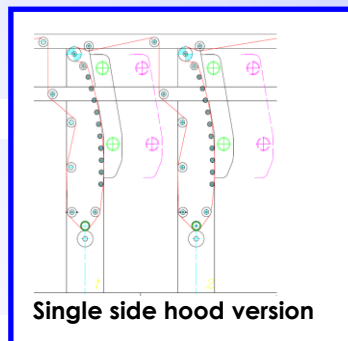

Single side hood version

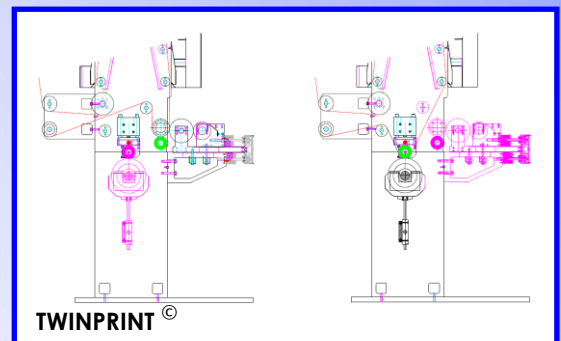

TWINPRINT<sup>®</sup>

**Your contact is:** Mr. Barry Taylor  
 Advanced Converting Equipment Ltd  
[sales@ace-machine.co.uk](mailto:sales@ace-machine.co.uk)  
 Mob: 00 44 (0) 7771 735875  
 Dir: 00 44 (0) 1200 442300  
[www.ace-machine.co.uk](http://www.ace-machine.co.uk)

Narrow Web Rotogravure NEXUS<sup>®</sup>