

ADVANCED CONVERTING EQUIPMENT

G H I B L I[®] Technical data:

Flexographic stack type printing units

- Web width..... 600- 1800mm
 - Max operating speed....350 m/min
 - Print repeat..... 320 –1000mm
 - Unwinder diameter..... up to 1200 mm
 - Rewinder diameter..... up to 1200 mm
 - Materials to print:
- Aluminium..... from 9my
 - OPP/BOPP/METBOPP... from 15 my
 - PET/METPET..... from 12 my
 - PVC Shrink-twistable..... from 28 my
 - OPA/BOPA..... from 20 my
 - Paper..... from 28 gsm
 - Cardboard..... Up to 250 gsm
 - Laminates..... Up to 250 gsm

Other features

- Digital tension control
- Automatic edge guiding system
- Digital AC motor drive SIEMENS
- Wide Touch Screen HMI 17"
- Operator friendly HMI - **NEXEASY[®]**
- Ethernet remote diagnostic
- Heating system: Electrical/Gas/thermal oil/ steam/IR
- Close chamber doctor blade system
- Possibility to be insert INLINE to bag making/extruder
- Sleeves system – On request
- UV curing – On request

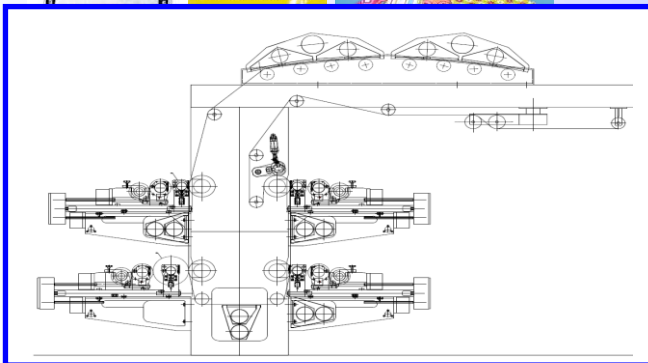

Your contact is: Mr. Barry Taylor
 Advanced Converting Equipment Ltd
sales@ace-machine.co.uk
 Mob: 00 44 (0) 7771 735875
 Dir: 00 44 (0) 1200 442300
www.ace-machine.co.uk

FLEXOGRAPHIC STACK TYPE G H I B L I[®]